



User and Technical Manual

HotDog Patient Warming System

Temperature Management Controller

Model WC7X

WC71 Single Port Controller

WC77 Multiport Controller

Manufactured by:

Augustine Temperature Management
6581 City West Parkway
Eden Prairie, MN 55344 USA
TEL: 952.465.3500
FAX: 952.465.3501
EMAIL: cs@aug surg.com
www.hotdogwarming.com

EU Authorized Representative:



EMERGO EUROPE
Prinsessegracht 20
2514 AP The Hague
The Netherlands

TEL (31) (0) 70 345-8570
FAX (31) (0) 70 346-7299



Contents

Introduction3

 Device Description3

 Indications for Use.....3

 Contraindications3

Warnings3

Cautions.....4

Precautions4

Initial Setup and Assembly.....5

 Contents5

 Mounting the Controller to an IV Pole5

Instructions for Use6

Temperature Monitoring and Auto Mode Guide.....8

Control Screen Overview10

Alarms and Alerts.....11

Cleaning the Controller12

Cleaning Warming Blankets and Mattresses.....12

 Frequently Asked Questions13

Accessories14

Definition of Product Symbols.....15

Technical Manual16

 Read Before Servicing Equipment16

Maintenance & Testing16

 Electrical Safety Checks and Functional Testing16

Specifications19

Electromagnetic Compatibility (EMC)21

Customer Service Contact

Phone: +1-952-465-3500

Email: CS@AugSurg.com

INTRODUCTION

Device Description

General Description:

The HotDog Patient Warming System consists of a Controller, reusable Warming Devices (e.g., Warming Blankets, Warming Mattresses), and other accessories.

It is the responsibility of the clinician to determine whether warming is appropriate for each individual patient. The System should not be used when clinical considerations indicate that warming of the patient is not advisable.

Core Temperature Monitoring / Auto Mode Description:

The Controller (WC7X) can measure patient core temperature from probes and function on AUTO mode whereby the Controller self-adjusts warming temperature settings based on the patient's core temperature.

The Controller can output the patient's temperature to patient monitors in order to provide information to the electronic medical record.

Indications for Use

General Indications for Use:

The HotDog Patient Warming System is intended to prevent or treat hypothermia and to provide warmth to patients. The System should be used in circumstances in which patients could become cold. The System can be used with adult and pediatric patients.

The System is intended primarily for use in hospitals and surgical centers including, without limitation, operating rooms, recovery rooms, emergency rooms, burn units and on other medical/surgical floors.

Core Temperature Monitoring / Auto Mode Indications for Use:

The Controller (WC7X) is intended to measure patient core temperature from probes and function on AUTO mode whereby the Controller self-adjusts warming temperature settings based on the patient's core temperature.

The System monitors the YSI 400-compatible temperature probes, checking for a valid internal patient temperature. YSI 400-compatible temperature probe parameters, such as patient body temperature values between 31°C and 43°C (inclusive) and valid slew rates of $\pm 1^\circ\text{C}$ per minute, are confirmed before allowing use in AUTO Mode.

Contraindications

- DO NOT warm ischemic or non-perfused tissue; thermal injury may result. Examples include tissue distal to aortic cross clamping or when vasoconstrictive drugs would lead to severe, prolonged vasoconstriction.
- DO NOT warm patients receiving transdermal medication; increased drug delivery may occur.

WARNINGS

General

- **EXPLOSION HAZARD – DO NOT** use the System in the presence of flammable anesthetics or highly oxygen-enriched environments such as hyperbaric chambers, oxygen tents, etc.
- **Inspect System components prior to each use** for signs of damage or excessive wear such as cuts, holes, or loose electrical connections or cold areas. If signs of wear are evident or if the warming device has been subjected to extreme physical force (e.g. pinched by clamps or run over by carts), do not use the product until it has been inspected by technical staff.

- **DO NOT** continue to use the System if the over-temperature indicator and/or any other alarms continue to sound after reset. Refer to the “Alarms and Alerts” section of this manual for more information.
- **Warning required per IEC 2-35 Standard:** use of materials of good thermal conductivity, such as water, gel, and similar substances, with the heating device not switched on can decrease the temperature of the body of a patient.

CAUTIONS

Federal law (USA) restricts this device to sale by or on the order of a licensed healthcare professional.

PRECAUTIONS

General

- Use under the direct supervision of a clinician.
- Monitor the patient’s vital signs regularly during warming according to institutional protocol. If vital sign instability occurs, notify the clinician.
- Care should be taken when using multiple warming methods.
- The risk of skin irritation caused by pooling of surgical prep solutions under the patient may increase with warming; ensure that surgical prep solution instructions for use are followed.
- Only plug an approved 3.5mm jack into T_{out} for the purposes of porting patient temperature data to the patient monitor.
- Dispose of the Controller per local regulations. Follow Warming Blanket and Mattress User Manuals for proper disposal.
- The Controller is designed to accept approved, YSI 400-compatible temperature probes. The temperature display range is 31C-43C. Resolution: 0.1C. Accuracy: $\pm 0.125^{\circ}\text{C}$. Functions as a “Direct Mode” thermometer, displaying the measured temperature from the site of measurement.
- Do not open the Controller. Only approved personnel can open the Controller for service. There are no user-serviceable parts. If service is required, contact Customer Service. The manufacturer assumes no responsibility for the reliability, performance, or safety of the System if any of the following occur:
 - The Controller is disassembled or serviced by an unauthorized person.
 - The System components are used in a manner other than described in the User Manuals.
 - The Controller is installed in an environment that does not meet the appropriate electrical and grounding requirements.
 - The Controller is grounded and attached to an un-grounded table intended for use with a hyfrecator or equivalent devices.

INITIAL SETUP & ASSEMBLY

Contents

The following components are included in the Controller shipping carton:

- 1—Controller Model WC7X
- 1—Mains power cord
- 1—IV pole adapter and mounting hardware
- 1—HotDog Warming Blanket Cable (P/N A101)

Reusable HotDog accessories are sold separately.

Mounting the Controller to an IV Pole

To mount the Controller to an IV pole, first secure the IV pole adapter to the Controller with the provided screws. Place the Controller IV pole adapter around the IV pole and turn the clamp handle clockwise until securely tightened (**Figure 1**).

Caution

To prevent the IV pole from tipping, attach the Controller at a height that provides stability. It is recommended to use an IV pole with a minimum wheelbase radius of 35.6 cm (14 in) and to mount the Controller no higher than 112 cm (44 in) from the floor. Failure to properly mount the Controller may cause the IV pole to tip, possibly resulting in injury.

Figure 1: Controller Mounted on an IV Pole

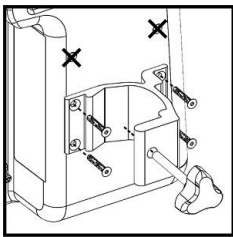
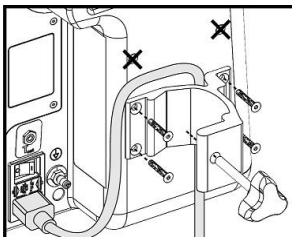
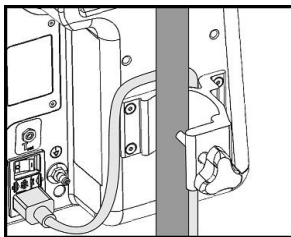
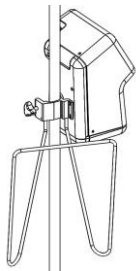
 <p>Line up the mounting clamp with the bottom two sets of screw holes. IMPORTANT: The clamp will not fit on the top two sets of screw holes.</p>	 <p>Ensure the power cable is in the clamp slot to strain relief cable. Tighten screws using supplied Allen wrench.</p>	 <p>Mount the Controller to the IV pole and tighten the clamp</p>	 <p>Optional storage rack sold separately. Attach if available.</p>
---	--	---	--

The back of the Controller features a standard VESA 75mm x 75mm interface, allowing for additional mounting options when using top and bottom holes. The provided IV pole clamp only works with the bottom four holes.

Rotate the clear cable-retention loop down on the side of the Controller. Use the loop to assist with cable management when the Controller is mounted to an IV pole.

INSTRUCTIONS FOR USE

The instructions below describe how to operate the Controller. For information about Warming Devices and accessories, refer to the User Manual provided with each item.

1. Insert the Controller power plug into a properly grounded hospital-grade electrical outlet. Turn on the Controller via the rocker switch at rear.

WARNING: To avoid risk of electric shock, this equipment must only be connected to a supply mains with protective earth grounding.

Note: The Controller is grounded and should not be attached to un-grounded tables intended for use with a hyfrecator or equivalent devices.

2. Position and secure the Device (e.g., Warming Blanket, Warming Mattress) following instructions in the User Manual for each device.
3. Insert the device’s connecting cable into the proper port on the Controller.

Table 1.

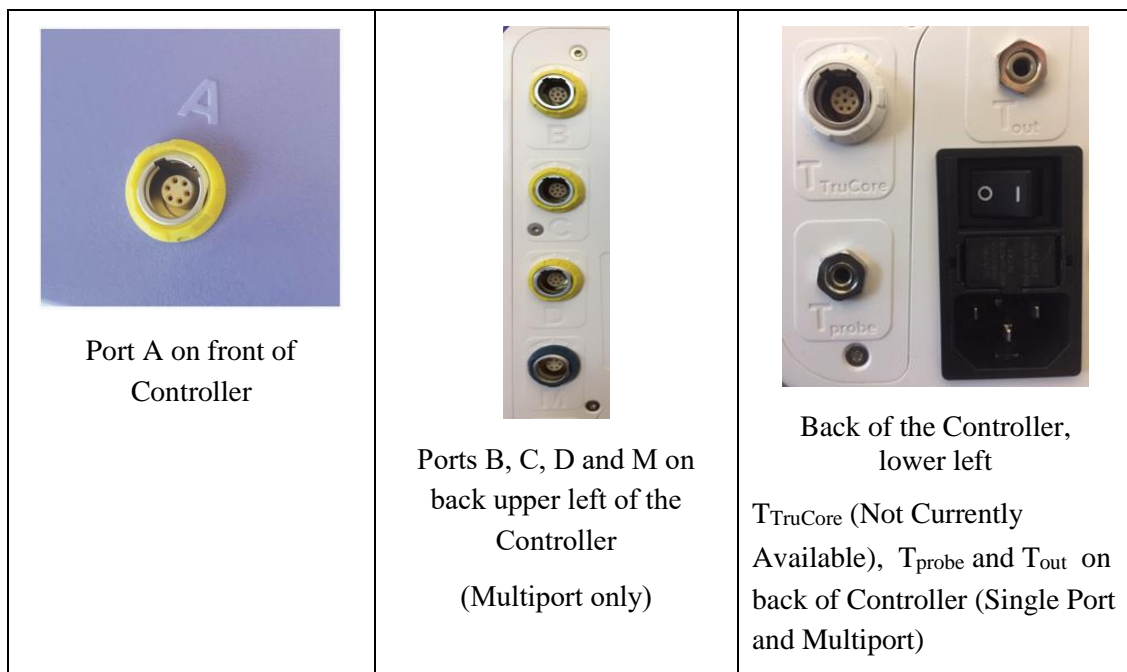

WC77 Multi Port	WC71 Single Port	Port Color	Device
A, B, C, D	A	Yellow	Warming Blanket, Clinician Vest
M		Blue	Warming Mattress
T _{probe} (In)	T _{probe} (In)	Silver	Patient Temperature Probe (3.5mm TSR jack)
T _{out}	T _{out}	Silver	3.5mm TR Jack (YSI 400 compatible output)

Figure 2: Controller Ports

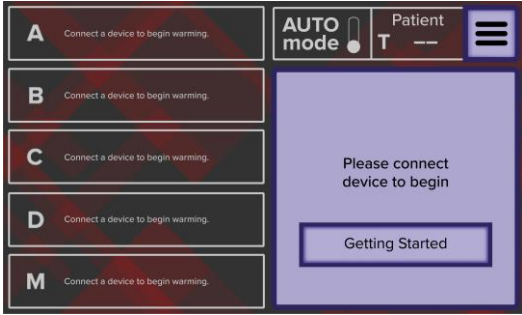

Note: When the connecting cable is inserted into the Controller, an audible sound indicates that the control sensor and over-temperature thermistor are present and functioning properly. The Port becomes available on the touchscreen.

4. Control Warming Devices using the touchscreen.

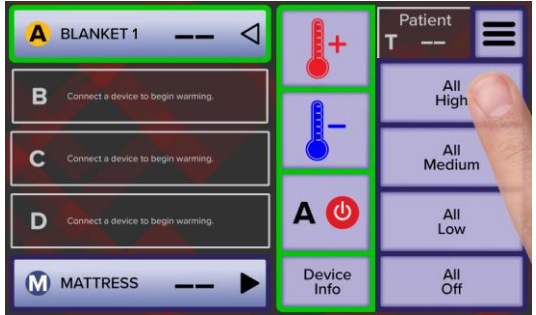
	
<ul style="list-style-type: none"> • Plug in a Warming Device to begin. When the cable is properly inserted into the Controller, an audible sound indicates that the Device is properly connected, and its port icon illuminates on the screen. 	<ul style="list-style-type: none"> • Touch the illuminated icon to activate.
	
<ul style="list-style-type: none"> • The Warming Device highlighted in green is the currently selected Device. To select its temperature, use the + thermometer to increase the temperature or the – thermometer to decrease the temperature. Turn off the highlighted port at the red power icon. 	<ul style="list-style-type: none"> • Each connected Warming Device can be adjusted separately. Other icons to the right adjust all port temperatures simultaneously: <ul style="list-style-type: none"> • All High • All Medium • All Low • All Off

5. If using a temperature probe and you wish to engage AUTO mode, see the instructions on pages 8 and 9.

6. When patient warming therapy is complete, turn the Mains Power Switch to OFF.

7. After use, disconnect the Controller from the electrical outlet.

TEMPERATURE MONITORING AND AUTO MODE GUIDE

1. This Controller can monitor patient core temperature when receiving a signal from a YSI 400-compatible temperature probe. This requires at least an A411-IN cable to make the connection. The Controller can also output the patient temperature to a third-party monitor (e.g. to port to the EMR). To output patient temperature to a third-party patient monitor, attach an industry-standard “headphone” jack (3.5mm mono) to the T_{out} port.
2. If utilizing an invasive temperature probe, esophageal or rectal probes are recommended for accuracy. Ensure the probe is correctly positioned in the patient, (or in the case of noninvasive probes, on the patient) and plug the probe into A411-IN cable, which must then be plugged into T_{probe} port. Note: If consistent with the temperature probe’s IFU, placement of an esophageal temperature probe should be past the initial “pressure” of the esophagus flattening by the heart. Pushing just past this point should yield accurate core temperature behind the heart.
3. While the Controller is awaiting a valid patient temperature from the probe, an hourglass displays next to the “T”. After a valid patient temperature has been established (31°-43°C & <1°C change / minute), the patient temperature will be displayed.
4. AUTO mode is available if Warming Devices are placed on the patient and plugged in and a valid human temperature is measured. AUTO mode automatically adjusts the Warming Device temperature settings based on a user-selectable “Normothermia Zone” in increments described in Table 2. The upper and lower limits of the Normothermia Zone are selectable in the *Menu - Settings - Temperature Graph*. The zone must extend 1°C or greater.
5. Note: While in AUTO mode, the clinician must still follow all indications and contraindications for use. For example, AUTO mode does not know whether a patient is aortic cross-clamped or if ischemic tissue is present: AUTO mode should never be used in these instances. The clinician must always be present during use. The clinician must ensure continual patient temperature monitoring and should not use AUTO mode on patients who are mobile (e.g. ICU patients who could dislodge their temperature probe). AUTO mode should not be used when temperature goals are other than simply rewarming (e.g. in certain cardiac surgery with forced cooling, followed by rewarming). Manual operation is recommended in these cases.

Table 2: AUTO mode -- Example					
Normothermia Zone (User Selectable)	Example Patient Temperature	Devices: All High	Devices: All Medium	Devices: All Low	Devices: All Off
>=Upper Limit Setting	38.0°C				X
67% of Upper Limit	37.3°C			X	
33% of Upper Limit	36.7°C		X		
<Lower Limit Setting	36.0°C	X			

Touchscreen Control -AUTO Mode Example

<p>a. This screen appears when valid conditions are present to operate in AUTO mode (Warming devices are plugged in and a valid patient temperature is detected).</p> <p>b. The clinician selects (✓) to engage AUTO mode.</p>	<p>c. AUTO Mode automatically sets all connected Warming Devices to the highest temperature setting. Patient temperature is displayed and logged for the case. Patient temperature data can be permanently logged to the EMR via the T_{out} port in increments of 0.1°C when using the appropriate cable. This prevents loss of data if power stops unexpectedly. Start time of AUTO is logged as T-0 for the duration of the case. Device warming settings are not logged.</p>
<p>d. When the predetermined level of patient normothermia is achieved, the Device's temperature settings are automatically adjusted downward in increments based on the percentage of the normothermia zone. See Table 2 on page 8 for an example.</p>	<p>e. Device remains in AUTO mode until the AUTO mode icon is deselected. The clinician can reenter AUTO mode by reselecting the AUTO mode icon. If the patient temperature is deemed invalid while in AUTO mode, the Controller will display an E7 Alert indicating that AUTO mode is disengaged. At this point the Warming Devices will turn to standby, and the clinician will need to operate warming manually.</p>

6. When patient warming therapy is complete, turn the Mains Power Switch to OFF.

7. After use, disconnect the Controller from the electrical outlet.

CONTROL SCREEN OVERVIEW

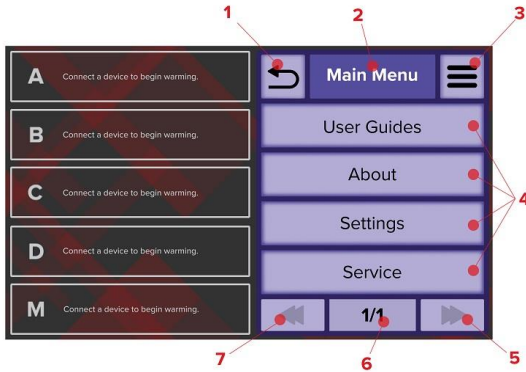
	<ol style="list-style-type: none"> 1. Back 2. Menu Title 3. Main Menu 4. Sub Menu 5. Next Page 6. Pages 7. Previous Page
---	---

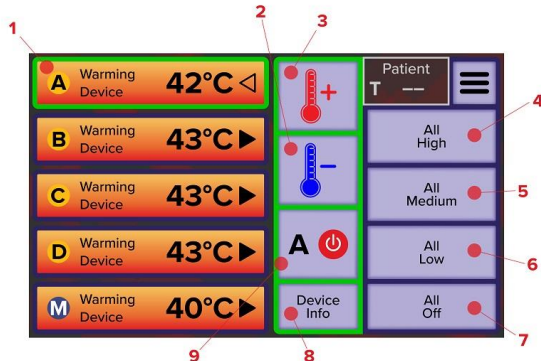
	<ol style="list-style-type: none"> 1. Currently Selected Device (green border) 2. Decrease Selected Device Temperature 3. Increase Selected Device Temperature 4. Set All Devices to High Temperature 5. Set All Devices to Medium Temperature 6. Set All Devices to Low Temperature 7. Turn Off All Devices 8. View Selected Device Info 9. Turn off Selected Device
--	--

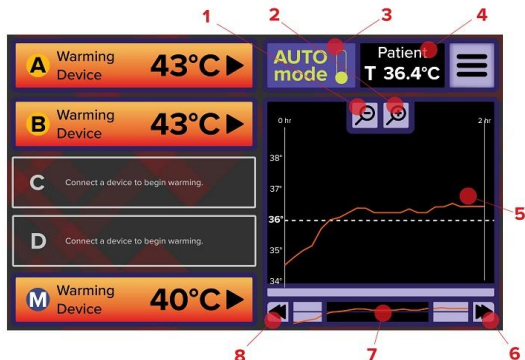
	<ol style="list-style-type: none"> 1. Zoom Out 2. Zoom In 3. Auto Mode switch (On/Off) 4. Patient Temperature “T” (TruCore (NA) or Probe) 5. Patient Temperature Graph 6. Scroll Right 7. Graph Overview 8. Scroll Left
---	---

Display Tips:

- A. Do not press down hard. This is not needed.
- B. An overly thick glove may prevent detection of finger.
- C. Moisture on screen can confuse the system; ensure screen is dry before use.

ALARMS AND ALERTS

NOTE: WARMING BLANKET OR MATTRESS WILL STOP WARMING IF AN ALARM CONDITION APPEARS

Error Codes	Error Description	Problem Solving Steps
E1	Over-Temperature	When the temperature exceeds one degree above the set point, the Alarm sounds and power is removed from the Warming Device. Unplug the Device to reset the Alarm. Wait 5 minutes and then reconnect the Device. Turn the Controller on and select the temperature. If the Alarm occurs again, stop using the Device and contact technical support.
E2	Failure To Reach Temp	When the Warming Device does not reach the temperature set point within 10 minutes, the Alarm sounds, and power is removed from the Device. Check to make sure the Device is in contact with a patient and the sensor area is touching the patient. Unplug the Device and reconnect to reset. If the Alarm occurs again, stop using the Device and contact technical support.
E3	Port Current Reached	If the electrical current in the Warming Device exceeds the allowable limit, the Alarm sounds and power is removed from the Device. This may indicate an electrical problem with the Device. Unplug the Device from the Controller and reconnect to reset. If the Alarm occurs again, stop using the Device and contact technical support.
E4	Sensor or Cable Failure	If the Controller loses communication with the sensor in the Warming Device, an Alarm sounds, and power is removed from the Device. This may be caused by an electrical problem in the Device or Controller. Swap the cables and Device with known good product to isolate the problem if possible. If the problem continues, stop using the Device or cable and contact technical support.
E5	Device Fold Detection	In Warming Device equipped with an over-temperature array, local overheating caused by folding of the Blanket causes an alarm, and power to the Blanket is turned off. Check the Blanket for folded areas. To reset Alarm, unplug the cable, wait 5 minutes and reconnect. If Alarm reoccurs, stop using the Blanket and contact technical support.
E7	Auto Mode Disengaged	Ensure proper placement of the Temperature Sensor to continue use of AUTO mode or manually control Warming Devices.
E8	Over-Temperature Sensor (Secondary)	The temperature sensor has exceeded 46° C. Disconnect the Warming Devices and contact technical support.
EA, EC, EF, EH or EP	Hardware Failure	Please turn off the Controller, wait one minute, and then restart. If the problem persists, contact technical support.

Contact Technical Support @ 952.465.3500 or CS@aug surg.com

Automatic Shutoff Timer - This feature prevents the System from unintentionally being left on. **The System is not intended for use without a clinician present.** The System defaults to a 6-hour automatic shutoff, if there is no interaction with the Controller. This time period can be adjusted for up to 24 hours, should it be required by the

case length. To adjust the automatic shutoff timer go to: Settings -> Automatic Shutoff Timer -> Use – or + to adjust the time.

CLEANING THE CONTROLLER

Warnings

- DO NOT use a dripping wet cloth, and DO NOT immerse the Controller in liquid. Moisture will damage the components, and thermal injury may result.

Precautions

- DO NOT use pure harsh solvents (e.g., MEK, acetone, etc.) or cleaners containing hydrogen peroxide to clean the Controller.

Frequency

As needed

Tools/Equipment

- Sponge or soft cloth
- Mild detergent or anti-microbial spray
- Dry soft cloth

Method

1. Disconnect the Controller from the power source before cleaning.
2. Wipe the Controller with a moistened sponge or soft cloth; avoid pushing fluids into any openings.
3. Dry with a separate soft cloth.

CLEANING WARMING BLANKETS AND MATTRESSES

Intro:

HotDog Warming Blankets and Mattresses are non-sterile electric warming devices for use in the operating room and in pre- and post-operative areas in healthcare facilities. Clean and disinfect Mattresses and Blankets between patient uses if they appear visibly soiled. If Mattresses and Blankets are not visibly soiled, disinfection at the end of the operating day is recommended.

Cautions:

Do not immerse Blankets or Mattresses in water. Do not use high-level disinfectants to clean Blankets or Mattresses. The CDC (USA) recommends against the use of high level disinfectants for cleaning environmental surfaces that may contact the patient since the chemicals are highly toxic. Do not spray cleaning solutions into the electrical connector.

Do not use peroxide-based cleaning solutions as these can adversely affect the internal heater. Do not place the Warming Devices in an autoclave, sterilizer, automatic washer - disinfectant, or any other high-temperature system as this may damage the Devices.

Cleaning Steps

Blankets and Mattresses should be cleaned following protocols for non-critical medical devices that may contact intact skin. Examples of similar devices are blood pressure cuffs, exam table covers, operating room table pads and

surgical supports. The cleaning steps are general recommendations and are not meant to replace hospital-specific cleaning protocols.

1. Avoid getting cleaning fluids into the electrical connector.
2. If visible body fluids or soiling are present, these must be removed before applying a disinfectant. Scrub the areas using detergent and a soft brush or sponge to remove any organic matter. Wipe the surface of the Warming Device with water using a dampened cloth. Do not immerse blankets in liquids.
3. Apply a low- or intermediate-level disinfectant to the entire Device by spraying or wiping. Follow the disinfectant manufacturer's application instructions to ensure adequate disinfection.
4. Following cleaning, ensure that the Device is dry before using again.

Frequently Asked Questions









































1. **How does HotDog work?** Blankets and Mattresses use a conductive polymer fabric called ThermAssure. A low voltage DC current flows over this light, flexible fabric, and the resistance generates even warmth. Blankets and Mattresses do not use carbon fiber or ink, which could break and create hot spots.
2. **Why is HotDog safe?** The Controller is really a microprocessor with many built-in safety features. It monitors connected Warming Devices at the patient and will automatically stop operation if readings are out of safe parameters. The Blankets and Mattresses use a low-voltage floating isolated DC current to warm. The flexible conductive polymer fabric generates uniform heat with no hot spots.
3. **Are the Blankets and Mattresses difficult to clean?** The cleaning process takes 30 seconds or less. The Warming Devices can be cleaned in the OR by wiping with a low- to intermediate-level disinfectant. Do not use with cleaners that contain hydrogen peroxide. The Warming Devices are designed for easy cleaning. The non-porous outer shell contains an anti-microbial and the edges are heat-sealed to eliminate crevices. The CDC says noncritical items like HotDog Blankets and Mattresses are safe and present virtually no risk of cross-contamination.
4. **Is there a greater risk of cross-contamination with reusable HotDog Blankets and Mattresses than with disposable FAW?** No. The Warming Devices are considered "non-critical items," meaning they only come in contact with intact skin. According to the CDC, "Virtually no risk has been documented for transmission of infectious agents to patients through noncritical items..." The risk of contamination may actually be greater with FAW. FAW is only partially disposable. The blower and hose are used with thousands of different patients, sometimes moving from one OR to another. One published study showed that 92% of FAW blowers are contaminated with bacteria, and 58% internally generated and emitted germ-sized particles (Albrecht, AJIC, 2011). The contamination is significant because high-velocity air blows across the germ colonies. The contaminated hot air vents under the drapes, mixes with "dirty" floor air and rises into the sterile field.
5. **How is HotDog safer for orthopedic surgeries?** Air-free HotDog patient warming is safer for surgeries involving implanted foreign materials—such as orthopedic and cardiac surgery—because there is no waste heat disrupting the sterile field with contaminants. Rising waste heat from forced-air warming contaminates the sterile surgical field above the table with dirty air from the floor by generating convection currents. There is a large body of peer-reviewed evidence published on this issue.
6. **How do I get the best warming results?** BODY SURFACE AREA: Warm as much surface area as possible. Warming the core is more effective than the periphery. EARLY START: Start warming as soon as the patient arrives in the OR. SENSOR CONTACT: Ensure that the sensor is in contact with the patient. THIN BARRIER: Use the thinnest barrier possible between the patient and the Warming Blankets or Mattress.

7. **Can the HotDog System be used in x-rays?** Yes. The heater fabric is completely radiolucent. However, each Warming Blanket and Mattress has parallel busbars that run along the long edge of the warming device. These can be seen on x-ray. In addition, the area around the sensor is also radio-opaque. If x-raying will be done (through the chest cavity, for example) then the Mattress should be positioned or rotated 180° such that the imaging area does not contain the sensor.
8. **Does HotDog offer any warming options for cases using steep Trendelenburg?** Yes. Procedures where the patient is positioned in steep Trendelenburg historically result in high rates of hypothermia due to the small surface area available for warming. The HotDog WaffleGrip Trendelenburg positioning accessory effectively prevents the patient from sliding on the table while still providing warmth under the patient.
9. **Why do HotDog blankets and mattresses expire?** Over time the electric current flowing over the conductive polymer fabric oxidizes it, changing its resistance and the time it needs to reach temperature. When new it only takes a few minutes to reach the set temperature. After 30 months of use it will take closer to 10 minutes to reach the set temperature. We have no data to support the use of the Devices beyond 30 months.

ACCESSORIES

Part Number	Description
B103	Lower Body Warming Blanket
B104	Full Body Warming Blanket
B105	Multi-position Warming Blanket
B107	Head Warming Blanket
B110	Chest and Torso Warming Blanket
B500	Universal Warming Blanket
B203	Small Lower Body Warming Blanket
B270	Small Pediatric Head Wrap
B271	Large Pediatric Head Wrap
S104	Lower and Full Body Disposable Sheet
U101	Underbody Warming Mattress, 82 cm (32in)
U102	Underbody Warming Mattress, 127 cm (50in)
U220	Pediatric Underbody Warming Mattress
U300	Trendelenburg Position Warming Mattress 89 cm (35in)
A101	Cable, Blanket, 4 meter, yellow
A102	Cable, Blanket, 5 meter, yellow
A108	Wire Storage Rack, IV Pole Mount
A109	Wire Storage Rack, Wall Mount
A110	Wire Storage Rack, WC7X Clamp-Mountable
A112	Cable, Mattress, 5 meter, blue
A300	Trendelenburg Positioning Kit
A301	Trendelenburg Positioning Kit with BackSaver Slide Sheet
A400-YSI400	Adapter - Output, 3.5mm TSF (headphone) — YSI 400 Series (1/4 in Phono)
A410-OUT	Cable, Output 3.5mm TSM-TSM (headphone male) 2 meter
A411-IN	Cable, NTC Input Cable extension 3.5mm TRSM-TRSF (2M)

DEFINITION OF PRODUCT SYMBOLS

	Do Not Place Under Patient		This Side Up		This Side Under Patient
	This Side Down		Heating Area		Medical Device
	Attention; consult accompanying documents		Reference Number		Lot Number
	BF Patient Applied Part according to IEC60601-1.		Serial Number		Manufacture Date
	Do not use after YYYY-MM-DD		Transport and storage temperature range		Manufacturer
	Keep Dry		Transport and storage humidity range		Fuse
	Equipotential		EU Authorized Representative		Return to Authorized Representative
	Temperature Sensor		Device Temperature Increase Button +1°C (When gray, device is at maximum temperature.)		Device Temperature Decrease Button -1°C (When gray, device is at minimum temperature.)
	Main Menu Button		Back Button		Next/Previous Page Graph Scroll Left/Right
	Confirm/Yes Button		Cancel/No Button		Increase Setting Button (Volume, Brightness, Etc.)
	Decrease Setting Button (Volume, Brightness, Etc.)		Graph Zoom in Button		Graph Zoom out Button
	Slideshow Play/Pause Button (Outline indicates pause)		Slideshow Volume Button		Alarm Mute Button (X indicates alarm is muted.)
	Conforms to Medical Device Regulation (OJ No L 117/1 of 2017-05-05)		See IFU for Warnings and Precautions		Medical Device restricted to sale by or on the order of a physician
	Measured temperature (invalid patient temperature)	T 37.0°C	Valid Patient Temperature (example)		
IPX2	Protected against dripping water when tilted up to 15°; vertically dripping water shall have no harmful effect when the enclosure is tilted at an angle up to 15° from its normal position.				
	Medical Equipment Classified by Intertek Testing Services NA Inc. with respect to electric shock, fire, and mechanical hazards only, in accordance with UL 60601-1 . Classified under the Medical Device Directive (93/42/EEC) as a Class IIb device.				

TECHNICAL MANUAL

Read Before Servicing Equipment

Repair, preventive maintenance, safety testing, and servicing of the System require the skill of qualified medical-equipment service technicians, who are familiar with good practice for medical device repair. Do not open the Controller. There are no user-serviceable parts. If service is required, contact Technical Support. Perform all maintenance activities in accordance with the instructions in this technical manual. Approved personnel: unplug the Warming Device before servicing internal components.

MAINTENANCE & TESTING

Electrical Safety Checks and Functional Testing

Frequency

These tests should be completed once every 24 months (or more frequently if required by hospital guidelines).

Tools/Equipment

- Warming Device Cable (A101 or A102, A112)
- Ground continuity tester
- Leakage current tester
- Calibrated, fast-reacting thermocouple and meter
- HotDog Warming Blanket or Warming Mattress (optional)

Method

1. Insert the Controller power plug into a properly grounded hospital-grade electrical outlet and confirm that no cables or devices are connected to any of the ports.

WARNING: To avoid risk of electric shock, this equipment must only be connected to a supply mains with protective earth ground.

Note: The Controller is grounded and should not be attached to un-grounded tables intended for use with a hyfrecator or equivalent devices.

2. Perform the following tests on the Controller per standard institutional protocol:
 - A. Ground continuity
 - B. Connect a Warming Blanket to the Controller and test leakage current to ensure the maximum leakage current does not exceed the requirements in **Table 3**.

	<p>Note: The equipotential stud on the back of the Controller may be used as a grounding point for these tests. Equipotential stud is for ease of attaining ground connection during electrical safety testing. Clip to stud during test. Reference 60601-1 8.6.7</p>
---	---

Table 3: Maximum Allowable Leakage Current		
Polarity	Condition	Current (mA)
Normal / Reversed	Normal	0.1
	Open Ground	0.5
	Open Neutral	0.5
	Open Ground & Open Neutral	0.5

1. Perform “Functional Testing” described on the following pages.

Functional Testing Method for Controller

Place the Controller in Diagnostic Test mode by navigating to the Service Menu (Main Menu>Service>Diagnostic Test). To run the Diagnostic Test, click the green checkmark button. **The test will not begin until all Warming Devices have been disconnected from the Controller.** If a failure is observed during any of these steps, call Customer Service.

To verify functionality of Alarms, Alarm should sound near the end of the test.

Per IEC 2-35: Test verifies that the independent thermal cut-out (i.e. secondary overtemperature sensor) is operational

When the test is successfully completed, “Passed” will display on the screen. If the test is unsuccessful, “Failed” will display.

Functional Testing for Blanket or Mattress and Controller

Use a Warming Blanket or Mattress to perform the steps outlined below. If a failure is observed during any of these steps, repeat testing using a different Warming Blanket or Mattress. If failure is observed with the second Warming Blanket or Mattress, contact Customer Service

1. Tape a calibrated, fast-reacting temperature sensor to the patient-facing surface of the Warming Blanket or Mattress directly over the sensor marking.
2. Fold the Warming Blanket or Mattress back on itself (black face to black face in the case of using a Warming Blanket) so that the temperature sensor is inside the folded area. Place a 750 to 1000g weight (such as a small book or notebook) over the sensor location to ensure that the Device remains folded and that there is good contact between the sensor and the folded Warming Blanket or Mattress.

Figure 3: Warming Blanket Test Configuration

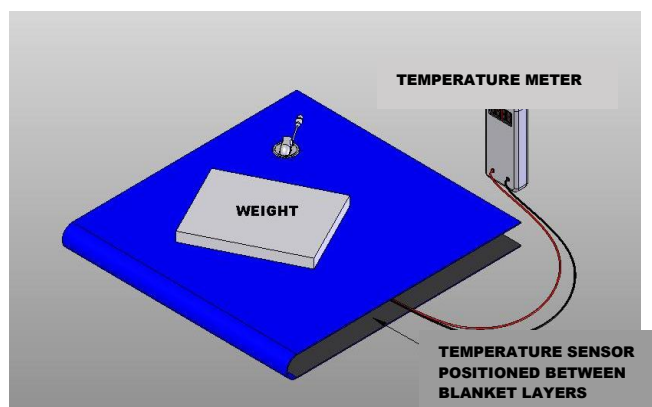

3. Turn the Mains Power Switch on the Controller to the ON position. Connect the Warming Blanket or Mattress cable to the Controller. *The Controller will emit an audible tone when the Warming Blanket or Mattress is connected.*
4. Set the Controller to the temperature that is to be verified. If checking all set-points, start with the low temperature.

5. After the Device reaches the set point (indicated when the set point readout is no longer flashing), allow the temperature to stabilize for an additional 10 minutes. *NOTE: A temperature overshoot will be noted when testing this way, which is normal.*
6. After 10 minutes, the reading on the temperature sensor should be within +/-1°C of the set-point temperature. When measuring temperature, the accuracy and tolerance of the sensor must be taken into account. This will depend on the type of sensor being used and can range from +/- 0.2°C to +/- 2.0°C. The measurement tolerance of the sensor must be added to the +/- 1.0°C tolerance for the System to determine the pass/fail criteria for this test. For example: If the Controller is set to 41°C, and the measurement is being made with a temperature sensor that has a +/- 1.0°C measurement tolerance, the acceptable range of measured temperatures will be 39 to 43°C. (i.e. 41 +/- 2°C).
7. Repeat steps 4-6 for the next temperature setting, if required.

Error Codes: Alerts & Alarms

When an Alarm or Alert condition occurs, the associated error code will remain on the display until the condition is resolved.

If multiple Alarm or Alert conditions occur sequentially, the code associated with the highest priority Alert condition will be displayed first, followed by the next highest priority alarm or alert condition until all Alarm or Alert conditions have been displayed to the user. Once all Alarm or Alert conditions have been displayed, the display will return to the main operating screen where the error codes will still be present on the screen in place of the temperature set point.

If a new Alarm or Alert condition occurs, all active Alarm or Alerts will be displayed to the user again sorted by priority as described above.

To resolve an Alarm, follow the on-screen instructions. Devices will not be active when an Alarm is occurring.

Alarm "audio paused" duration is 10 minutes, after which time audio resumes.

Alert Error Condition	Code		Alarm Error Condition	Code
Calibration failure	EA		Overcurrent (System)	E3
Hardware failure (secondary circuitry)	EC		Primary Over-temperature	E1
System Failure (Power Switch Failure)	EF		Port Current Limit Reached	E3
Hardware I2C failure	EH		Sensor or Cable Failure	E4
Hardware power supply failure	EP		Blanket Fold Detection	E5
Failure to Reach Temp	E2		Over Temperature (Secondary)	E8
Auto mode Disengaged	E7			
Automatic Shutoff Timer	-- (returns to Standby mode)			

Alarm Error Condition	Code	Condition Delay	Signal Generation Delay (Software Alarm)	Signal Generation Delay (Hardware Alarm)
Overcurrent (System) [hardware]	E3	< 1 millisecond	< 200 milliseconds	< 50 seconds
Primary Over-temperature [software]	E1	15 Sec	< 200 milliseconds	(software only; won't alarm)
Port Current Limit Reached [hardware]	E3	< 1 millisecond	< 200 milliseconds	< 50 seconds
Sensor or Cable Failure [software]	E4	15 Sec	< 200 milliseconds	(software only; won't alarm)
Blanket Fold Detection [software]	E5	15 Sec	< 200 milliseconds	(software only; won't alarm)
Over Temperature TruCore (NA) [hardware]	E6	< 1 millisecond	Not implemented	< 50 seconds
Over Temperature (Secondary) [hardware]	E8	< 1 millisecond	< 200 milliseconds	< 50 seconds

SPECIFICATIONS

Physical Characteristics	
Dimensions	28 cm high x 17.8 cm deep x 22.2 cm wide (11" high x 7" deep x 8.75" wide)
Weight	2.8-3.2 kg (6.25 – 7.15 lbs.) without the clamp
Mounting	Can be placed on a horizontal flat surface (i.e. table top), clamped to an IV pole, or hung using a VESA mount of either FDMI MIS-C (35 × 75 mm) or FDMI MIS-D (75 × 75 mm) specifications
Temperature Characteristics	
Temperature Control	Micro-processor
Operating Temperatures	Blanket Ports A, B, C, and D adjustable in 1°C increments 37° to 43° ± 1.0°C 98.6° to 109.4° ± 1.8°F
	Mattress Port M adjustable in 1°C increments 35° to 40° ± 1.0°C 95° to 104° ± 1.8°F
Safety System	
All alarm conditions are classified as Medium Priority Technical Alarms	
Auditory Alarms	Minimum SPL of 65 dB(A) at 3m (from front of controller) with a back ground SPL not to exceed 55dB(A)
Primary Over-temp Alarm	Ports A, B, C, D (Warming Blanket) Medium Priority Alarm sounds when temperature sensor is at set point + 1°C
	Port M (Warming Mattress) Medium Priority Alarm sounds when temperature sensor at set point + 1°C
Secondary Over-temp Alarm	Ports A, B, C, D (Warming Blanket)

	<p>Independent electronic circuit shuts the heater off if the Warming Blanket temperature sensor reaches max set point + 3°C. (46°C) Medium Priority Alarm sounds.</p> <p>Port M (Warming Mattress)</p> <p>Independent electronic circuit shuts the heater off if the Warming Mattress temperature sensor reaches max set point ± 2.5°C (42.5°C) Medium Priority Alarm sounds.</p>																	
Over-current limits	<table border="1"> <tr><td>Port A</td><td>10 amps max</td></tr> <tr><td>Port B</td><td>10 amps max</td></tr> <tr><td>Port C</td><td>10 amps max</td></tr> <tr><td>Port D</td><td>10 amps max</td></tr> <tr><td>Port M</td><td>7 amps max</td></tr> <tr><td>Port T</td><td>1 amp max</td></tr> <tr><td>Trucore</td><td></td></tr> <tr><td>System</td><td>14.6 amps</td></tr> </table>	Port A	10 amps max	Port B	10 amps max	Port C	10 amps max	Port D	10 amps max	Port M	7 amps max	Port T	1 amp max	Trucore		System	14.6 amps	<p>Medium Priority Alarm sounds in over current condition. System utilizes power rationing when multiple ports are drawing current over system levels.</p>
Port A	10 amps max																	
Port B	10 amps max																	
Port C	10 amps max																	
Port D	10 amps max																	
Port M	7 amps max																	
Port T	1 amp max																	
Trucore																		
System	14.6 amps																	
System Over-current Protection	Dual input fused lines. Medium Priority Alarm sounds																	
Electrical Characteristics																		
Leakage Current	Meets UL 60601-1 and IEC 60601-1 requirements for Class I, Type BF equipment.																	
Power Consumption	850W maximum																	
Power Cord	4.6 m (15 ft) - May vary by country and region per local requirements and regulations.																	
Device Ratings	<p>Input: 100-240 VAC, 50/60 Hz, 850VA</p> <p>Output A, B, C, D: 48 VDC, 480 VA Max each</p> <p>Output M: 336 VA Max</p>																	
Fuses	T10AL250V (2 x 5x20mm)																	
Environmental Conditions																		
Environmental Conditions for Transport and Storage	<p>Temperature: -20°C to 60°C</p> <p>Humidity: 20% to 80%</p> <p>Keep Dry</p>																	
Environmental Conditions for Use	<p>Temperature: 15°C to 25°C</p> <p>Humidity: 20% to 80%</p>																	
Technical Description of PCLCS (physiologic closed-loop control system) – AUTO mode -- per IEC 60601-1-10 ed. 1.1																		
Accompanying Information From Table C.3	Details necessary for the safe use of a DISTRIBUTED PCLCS 6.4	NA - Not a distributed PCLCS																
	Summary of the PCLC modes of operation and specification of PCLCS responses 8.2.2.6	See Table 2 in IFU																
	Means to check responses of the PCLCS 8.2.2.6	If patient temperature is outside a normal range, AUTO mode is disengaged and E7 alert is initiated.																
Classification and Standards																		
Certifications	<p>IEC 60601-1; EN 60601-1-2; UL 60601-1; CAN/CSA-C22.2, No. 601.1, EN 55011</p> 																	
Classification	<p>Classified under IEC 60601-1 Guidelines (and other national versions of the Guidelines) as Class I, Type BF, Ordinary equipment, Continuous operation. Not suitable for use in presence of flammable anesthetic mixtures with air or with oxygen or nitrous oxide. Classified by Intertek Testing Services NA Inc. with respect to electric shock, fire, and mechanical hazards only, in accordance with UL 60601-1. Classified under the Medical Device Directive (93/42/EEC) as a Class IIb device. Classified under the Canadian Medical Device Regulation as Class II.</p>																	
Diagnostics	A qualified technician can perform general system testing. The Controller has no user serviceable parts.																	

<p>Important Information</p>	<p>This device complies with the EMC requirements according to IEC 60601-1-2. Radio transmitting equipment, cellular phones, etc. shall not be used in the close proximity of the device since this could influence the performances of the device. Particular precaution must be considered during use of strong emission sources such as High Frequency surgical equipment and similar so that, e.g., the HF-cables are not routed on or near the device. If in doubt, contact a qualified technician or your local representative.</p>																																
<p>Essential Performance</p>																																	
	<p>1. If the applied part cannot reach set point within 10 minutes, the warming device shall turn off and a low priority technical alert shall be generated</p> <p>2. Minimum watt density of the heater shall be sufficient to achieve clinically effective warming (0.10 watts per square inch (155 watts per square meter))</p> <p>3. Maximum watt density of the heater shall be less than 0.45 watts per square inch (620 watts per square meter)</p> <p>4. Patient contact surfaces of the HotDog System shall operate at a set point +/- 5°C at steady state when device is under even thermal load</p> <p>5. The thermal storage capacity of the applied part shall be less than 100% of the power output of the heater</p> <p>6. In normal or single fault conditions, the warming device shall not raise skin temperature above 43°C. If skin temperatures exceed 43°C, they will stay within the following time/temperature limits:</p> <table border="1" data-bbox="805 875 1136 1310"> <thead> <tr> <th>Time (s)</th> <th>Temperature (C)</th> </tr> </thead> <tbody> <tr><td>10000</td><td>43.5</td></tr> <tr><td>6000</td><td>44</td></tr> <tr><td>3300</td><td>44.5</td></tr> <tr><td>1990</td><td>45</td></tr> <tr><td>1000</td><td>45.5</td></tr> <tr><td>600</td><td>46</td></tr> <tr><td>350</td><td>46.5</td></tr> <tr><td>225</td><td>47</td></tr> <tr><td>110</td><td>47.5</td></tr> <tr><td>80</td><td>48</td></tr> <tr><td>60</td><td>48.5</td></tr> <tr><td>38</td><td>49</td></tr> <tr><td>28</td><td>49.5</td></tr> <tr><td>22</td><td>50</td></tr> <tr><td>17</td><td>50.5</td></tr> </tbody> </table>	Time (s)	Temperature (C)	10000	43.5	6000	44	3300	44.5	1990	45	1000	45.5	600	46	350	46.5	225	47	110	47.5	80	48	60	48.5	38	49	28	49.5	22	50	17	50.5
Time (s)	Temperature (C)																																
10000	43.5																																
6000	44																																
3300	44.5																																
1990	45																																
1000	45.5																																
600	46																																
350	46.5																																
225	47																																
110	47.5																																
80	48																																
60	48.5																																
38	49																																
28	49.5																																
22	50																																
17	50.5																																

ELECTROMAGNETIC COMPATIBILITY (EMC)

The System requires special precautions regarding EMC and must be installed and put into service according to the EMC information provided in this User Manual.

Warning

- Warning per IEC 1-2 Standard:
 - Use of this equipment adjacent to or stacked with other equipment should be avoided because it could result in improper operation. If such use is necessary, this equipment and the other equipment should be observed to verify that they are operating normally.
 - Use of accessories, transducers, and cables other than those specified or provided by the manufacturer of this equipment could result in increased electromagnetic emissions or decreased electromagnetic immunity of this equipment and result in improper operation.
 - Portable RF communications equipment (including peripherals such as antenna cables and external antennas) should be used no closer than 30 cm (12 inches) to any part of the WC7X, including cables specified by the manufacturer. Otherwise, degradation of the performance of this equipment could result.

Guidance and Manufacturer’s Declaration – Electromagnetic Emissions		
The HotDog™ Patient Warming System is intended for use in the electromagnetic environment specified below. The customer or user of the HotDog Patient Warming System should assure that it is used in such an environment.		
Emissions test	Compliance	Electromagnetic Environment – Guidance
RF emissions, CISPR 11	Group 1	The HotDog Patient Warming System uses RF energy only for its internal function. Therefore, its RF emissions are very low and are not likely to cause any interference in nearby electronic equipment.
RF emissions, CISPR 11	Class A	NOTE The EMISSIONS characteristics of this equipment make it suitable for use in industrial areas and hospitals (CISPR 11 class A). If it is used in a residential environment (for which CISPR 11 class B is normally required) this equipment might not offer adequate protection to radio-frequency communication services. The user might need to take mitigation measures, such as relocating or re-orienting the equipment.
Harmonic emissions, IEC 61000-3-2	Class A	
Voltage fluctuations/ flicker emissions, IEC 61000-3-3	Complies	

Guidance and Manufacturer’s Declaration – Electromagnetic Immunity			
The HotDog™ Patient Warming System is intended for use in the electromagnetic environment specified below. The customer or the user of the HotDog Patient Warming System should assure that it is used in such an environment.			
Immunity Test	IEC 60601 Test Level	Compliance Level	Electromagnetic Environment – Guidance
Electrostatic discharge (ESD) IEC 61000-4-2	±2, 4, 8 kV contact ±2, 4, 8, 15 kV air	±2, 4, 8 kV contact ±2, 4, 8, 15 kV air	Floors should be wood, concrete or ceramic tile. If floors are covered with synthetic material, the relative humidity should be at least 30 %.
Electrical fast transient/burst IEC 61000-4-4	±2 kV for power supply lines ±1 kV for input/output lines	±2 kV for power supply lines ±1 kV for input/output lines	Mains power quality should be that of a typical commercial or hospital environment.
Surge IEC 61000-4-5	±1 kV line(s) to line(s) ±2 kV line(s) to earth	±1 kV line(s) to line(s) ±2 kV line(s) to earth	Mains power quality should be that of a typical commercial or hospital environment.
Voltage dips, short interruptions and voltage variations on power supply input lines IEC 61000-4-11	0% <i>UT</i> for 0,5 cycle (0-315° with 45° increments) 0% <i>UT</i> (100 % dip in <i>UT</i>) for 1 cycles 70 % <i>UT</i> (30 % dip in <i>UT</i>) for 25/30 cycles 0 % <i>UT</i> (100 % dip in <i>UT</i>) for 5 sec	0% <i>UT</i> for 0,5 cycle (0-315° with 45° increments) 0% <i>UT</i> (100 % dip in <i>UT</i>) for 1 cycles 70 % <i>UT</i> (30 % dip in <i>UT</i>) for 25/30 cycles 0% <i>UT</i> (100 % dip in <i>UT</i>) for 5 sec	Mains power quality should be that of a typical commercial or hospital environment. If the user of the HotDog Patient Warming System requires continued operation during power mains interruptions, it is recommended that the HotDog Patient Warming System be powered from an uninterruptible power supply or a battery.
Power frequency 50/60 Hz) magnetic field IEC 61000-4-8	30 A/m	30 A/m	Power frequency magnetic fields should be at levels characteristic of a typical location in a typical commercial or hospital environment.

NOTE *UT* is the a.c. mains voltage prior to application of the test level.

Guidance and Manufacturer’s Declaration – Electromagnetic Immunity (cont’d)

The HotDog™ Patient Warming System is intended for use in the electromagnetic environment specified below. The customer or the user of the HotDog Patient Warming System should assure that it is used in such an environment.

Immunity Test	IEC 60601 Test Level	Compliance Level	Electromagnetic Environment – Guidance
Conducted RF IEC 61000-4-6	3 Vrms with 6 Vrms in ISM bands 150 kHz to 80 MHz	3 V, and 6 Vrms	Portable and mobile RF communications equipment should be used no closer to any part of the HotDog Patient Warming System, including cables, than the recommended separation distance calculated from the equation applicable to the frequency of the transmitter. Recommended separation distance $d = 1,2\sqrt{P}$ $d = 0,35\sqrt{P}$ 80 MHz to 800 MHz $d = 0,7\sqrt{P}$ 800 MHz to 2,5 GHz where <i>P</i> is the maximum output power rating of the transmitter in watts (W) according to the transmitter manufacturer and <i>d</i> is the recommended separation distance in metres (m). Field strengths from fixed RF transmitters, as determined by an electromagnetic site survey, ^a should be less than the compliance level in each frequency range. ^b Interference may occur in the vicinity of equipment marked with the following symbol: 
Radiated RF IEC 61000-4-3	10 V/m 80 MHz to 2,7 GHz	10 V/m	

NOTE 1 At 80 MHz and 800 MHz, the higher frequency range applies.
 NOTE 2 These guidelines may not apply in all situations. Electromagnetic propagation is affected by absorption and reflection from structures, objects and people.

^a Field strengths from fixed transmitters, such as base stations for radio (cellular/cordless) telephones and land mobile radios, amateur radio, AM and FM radio broadcast and TV broadcast cannot be predicted theoretically with accuracy. To assess the electromagnetic environment due to fixed RF transmitters, an electromagnetic site survey should be considered. If the measured field strength in the location in which the HotDog Patient Warming System is used exceeds the applicable RF compliance level above, the HotDog Patient Warming System should be observed to verify normal operation. If abnormal performance is observed, additional measures may be necessary, such as reorienting or relocating the HotDog Patient Warming System.
^b Over the frequency range 150 kHz to 80 MHz, field strengths should be less than 3 V/m.

Recommended separation distances between portable and mobile RF communications equipment and the HotDog Patient Warming System

The HotDog Patient Warming System is intended for use in an electromagnetic environment in which radiated RF disturbances are controlled. The customer or the user of the System can help prevent electromagnetic interference by maintaining a minimum distance between portable and mobile RF communications equipment (transmitters) and the System as recommended below, according to the maximum output power of the communications equipment.

Rated maximum output power of transmitter W	Separation distance according to frequency of transmitter m		
	150 kHz to 80 MHz $d = 1,2\sqrt{P}$	80 MHz to 800 MHz $d = 0,35\sqrt{P}$	800 MHz to 2,5 GHz $d = 0,7\sqrt{P}$
0,01	0,12	0,04	0,07
0,1	0,37	0,11	0,22
1	1,2	0,35	0,70
10	3,7	1,1	2,2
100	12	3,5	7,0

For transmitters rated at a maximum output power not listed above, the recommended separation distance d in metres (m) can be estimated using the equation applicable to the frequency of the transmitter, where P is the maximum output power rating of the transmitter in watts (W) according to the transmitter manufacturer.

NOTE 1 At 80 MHz and 800 MHz, the separation distance for the higher frequency range applies.

NOTE 2 These guidelines may not apply in all situations. Electromagnetic propagation is affected by absorption and reflection from structures, objects and people.

Customer Service Contact Phone: +1-952-465-3500 Email: CS@AugSurg.com

HotDog is a trademark of Augustine Temperature Management, registered in the U.S. Patent & Trademark Office. Devices are protected by some or all of the following patents: (US Patents 7,543,344; 7,714,255; 7,851,729; 7,786,408; 8,062,343; 8,283,602; 8,604,391; 8,624,164; 8,772,676; 8,986,359; 9,962,122; 9,668,303; 10,154,543; 10,201,935; 10,206,248; 10,506,668; PCT Patent EP 2,062,460).

Other patents are pending.